

어썬 DRILL &
A'some **ENDMILL SERIES**

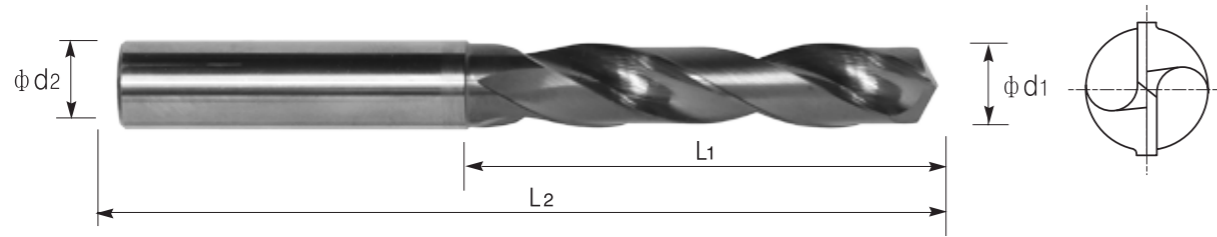

A'some DRILL

SOLID CARBIDE DRILL REGULAR TYPE



드릴직경 Diameter	날길이 Length of Cut	온길이 Overall length	샹크직경 Shank Dia
D1	L1	L2	D2
3.0~4.0	25	60	4
4.1~5.0	25	60	5
5.1~6.0	25	60	6
6.1~7.0	35	60	7
7.1~8.0	35	80	8
8.1~9.0	35	80	9
9.1~10.0	35	80	10
10.1~11.0	50	108	11
11.1~12.0	60	108	12
12.1~13.0	60	108	13
13.1~14.0	60	108	14
14.1~15.0	60	108	15
15.1~16.0	60	108	16
16.1~17.0	60	108	17
17.1~18.0	60	108	18

A'some DRILL-LONG TYPE

SOLID CARBIDE DRILL LONG TYPE

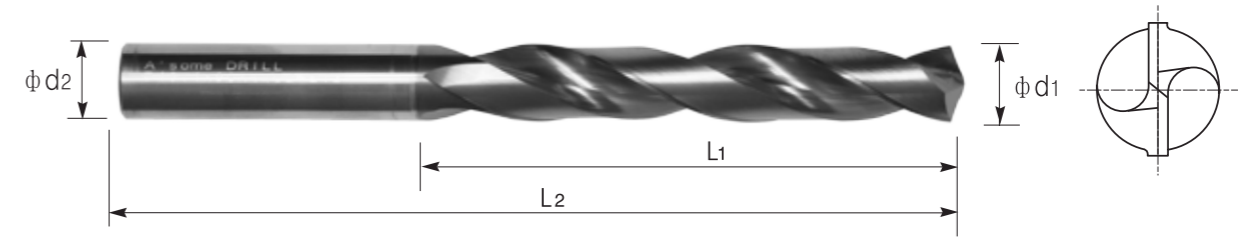

드릴직경 Diameter	날길이 Length of Cut	온길이 Overall length	샹크직경 Shank Dia
D1	L1	L2	D2
3.0~4.0	35	82	4
4.1~5.0	35	82	5
5.1~6.0	35	82	6
6.1~7.0	60	108	7
7.1~8.0	60	108	8
8.1~9.0	60	108	9
9.1~10.0	60	108	10
10.1~11.0	80	150	11
11.1~12.0	80	150	12
12.1~13.0	80	150	13
13.1~14.0	80	150	14
14.1~15.0	80	150	15
15.1~16.0	90	160	16
16.1~17.0	90	160	17
17.1~18.0	90	160	18

A'some ENDMILL-2F

CARBIDE ENDMILL

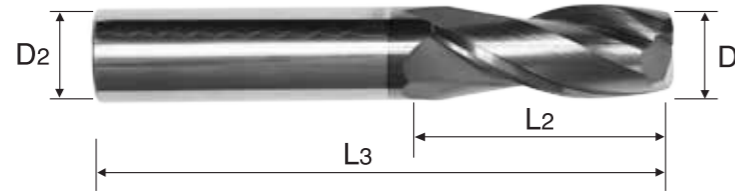

A'some ENDMILL-4F

CARBIDE ENDMILL

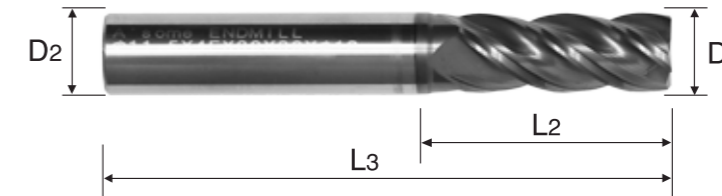

외경 Diameter	날길이 Length of Cut	온길이 Overall length	상크직경 Shank Dia	외경 Diameter	날길이 Length of Cut	온길이 Overall length	상크직경 Shank Dia
D	L2	L3	D2	D	L2	L3	D2
D3.0	15	60	6	D10.0	30	80	10
D3.5	15	60	6	D10.5	30	80	12
D4.0	15	60	6	D11.0	30	80	12
D4.5	15	60	6	D11.5	30	80	12
D5.0	15	60	6	D12.0	30	80	12
D5.5	15	60	6	D13.0	30	80	12
D6.0	15	60	6	D14.0	30	80	16
D6.5	15	60	8	D15.0	30	80	16
D7.0	15	60	8	D16.0	45	108	16
D7.5	15	60	8	D17.0	45	108	16
D8.0	30	80	8	D18.0	45	108	16
D8.5	30	80	10	D19.0	45	108	20
D9.0	30	80	10	D20.0	45	108	20
D9.5	30	80	10				

외경 Diameter	날길이 Length of Cut	온길이 Overall length	상크직경 Shank Dia	외경 Diameter	날길이 Length of Cut	온길이 Overall length	상크직경 Shank Dia
D	L2	L3	D2	D	L2	L3	D2
D3.0	15	60	6	D10.0	30	80	10
D3.5	15	60	6	D10.5	30	80	12
D4.0	15	60	6	D11.0	30	80	12
D4.5	15	60	6	D11.5	30	80	12
D5.0	15	60	6	D12.0	30	80	12
D5.5	15	60	6	D13.0	30	80	12
D6.0	15	60	6	D14.0	30	80	16
D6.5	15	60	8	D15.0	30	80	16
D7.0	15	60	8	D16.0	45	108	16
D7.5	15	60	8	D17.0	45	108	16
D8.0	30	80	8	D18.0	45	108	16
D8.5	30	80	10	D19.0	45	108	20
D9.0	30	80	10	D20.0	45	108	20
D9.5	30	80	10				

A'some ENDMILL-LONG TYPE 2F

CARBIDE ENDMILL LONG TYPE

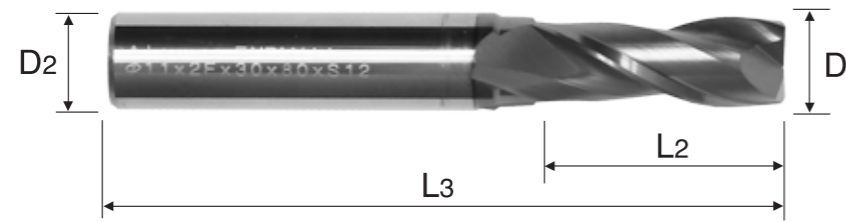

외경 Diameter	날길이 Length of Cut	온길이 Overall length	상크직경 Shank Dia	외경 Diameter	날길이 Length of Cut	온길이 Overall length	상크직경 Shank Dia
D	L2	L3	D2	D	L2	L3	D2
D3.0	30	80	6	D10.0	40	108	10
D3.5	30	80	6	D10.5	50	108	12
D4.0	30	80	6	D11.0	50	108	12
D4.5	30	80	6	D11.5	50	108	12
D5.0	30	80	6	D12.0	50	108	12
D5.5	30	80	6	D13.0	50	108	12
D6.0	30	80	6	D14.0	50	108	16
D6.5	30	80	8	D15.0	50	108	16
D7.0	30	80	8	D16.0	70	160	16
D7.5	30	80	8	D17.0	70	160	16
D8.0	40	108	8	D18.0	70	160	16
D8.5	40	108	10	D19.0	70	160	20
D9.0	40	108	10	D20.0	70	160	20
D9.5	40	108	10				

A'some ENDMILL-LONG TYPE 4F

CARBIDE ENDMILL LONG TYPE

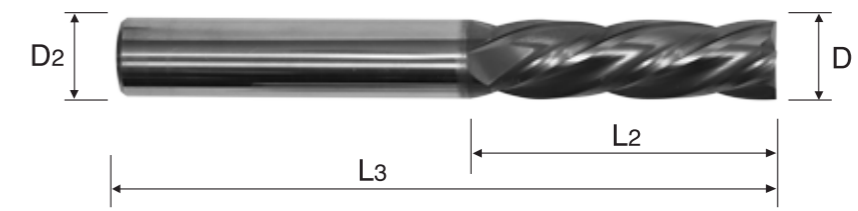

외경 Diameter	날길이 Length of Cut	온길이 Overall length	상크직경 Shank Dia	외경 Diameter	날길이 Length of Cut	온길이 Overall length	상크직경 Shank Dia
D	L2	L3	D2	D	L2	L3	D2
D3.0	30	80	6	D10.0	40	108	10
D3.5	30	80	6	D10.5	50	108	12
D4.0	30	80	6	D11.0	50	108	12
D4.5	30	80	6	D11.5	50	108	12
D5.0	30	80	6	D12.0	50	108	12
D5.5	30	80	6	D13.0	50	108	12
D6.0	30	80	6	D14.0	50	108	16
D6.5	30	80	8	D15.0	50	108	16
D7.0	30	80	8	D16.0	70	160	16
D7.5	30	80	8	D17.0	70	160	16
D8.0	40	108	8	D18.0	70	160	16
D8.5	40	108	10	D19.0	70	160	20
D9.0	40	108	10	D20.0	70	160	20
D9.5	40	108	10				

A'some RADIUS ENDMILL-2F

CARBIDE CORNER RADIUS ENDMIL

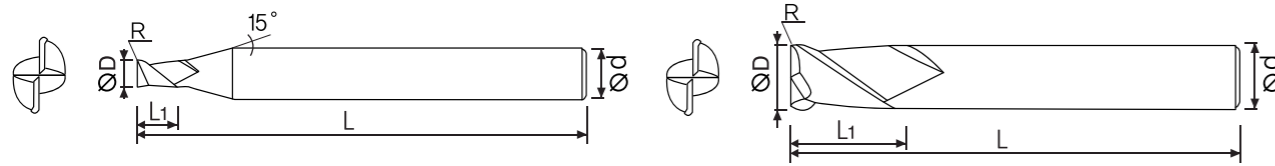

외경 Diameter	코너R Corner R	날 장 Length of Cut	전 장 Overall length	샙크경 Shank Dia	외경 Diameter	코너R Corner R	날 장 Length of Cu	전 장 Overall length	샙크경 Shank Dia
D	R	L1	L	d	D	R	L1	L	d
2.0	R0.1	3.4	50	6	6.0	R0.3	10	50	6
2.0	R0.2	3.4	50	6	6.0	R0.5	10	50	6
2.0	R0.3	3.4	50	6	6.0	R1.0	10	50	6
2.0	R0.5	3.4	50	6	6.0	R1.5	10	50	6
2.5	R0.2	4.2	50	6	6.0	R1.2	10	50	6
2.5	R0.3	4.2	50	6	8.0	R0.2	14	60	8
2.5	R0.5	4.2	50	6	8.0	R0.3	14	60	8
3.0	R0.1	5.0	50	6	8.0	R0.5	14	60	8
3.0	R0.2	5.0	50	6	8.0	R1.0	14	60	8
3.0	R0.3	5.0	50	6	8.0	R1.5	14	60	8
3.0	R0.5	5.0	50	6	8.0	R1.2	14	60	8
3.0	R1.0	5.0	50	6	10.0	R0.2	16	70	10
4.0	R0.2	7.0	50	6	10.0	R0.5	16	70	10
4.0	R0.3	7.0	50	6	10.0	R1.0	16	70	10
4.0	R0.5	7.0	50	6	10.0	R1.5	16	70	10
4.0	R1.0	7.0	50	6	10.0	R2.0	16	70	10
5.0	R0.1	7.0	50	6	12.0	R0.2	20	80	12
5.0	R0.2	8.0	50	6	12.0	R0.3	20	80	12
5.0	R0.3	8.0	50	6	12.0	R0.5	20	80	12
5.0	R0.5	8.0	50	6	12.0	R1.0	20	80	12
6.0	R0.1	10	50	6	12.0	R2.0	20	80	12
6.0	R0.2	10	50	6					

A'some RADIUS ENDMILL-4F

CARBIDE CORNER RADIUS ENDMILL

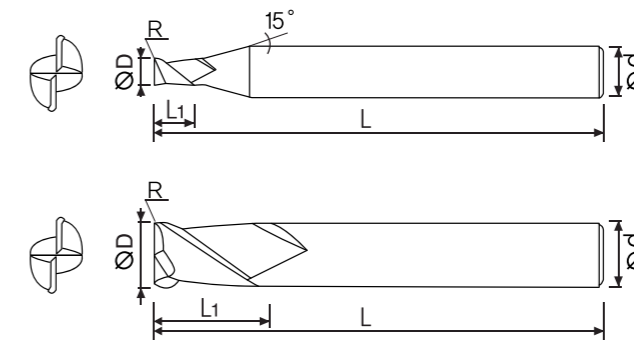
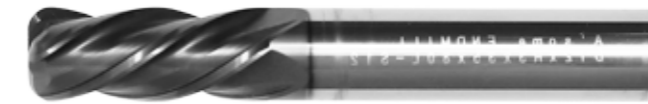

외경 Diameter	코너R Corner R	날 장 Length of Cut	유효장 Length of Cut Valid	전 장 Overall length	샙크경 Shank Dia	외경 Diameter	코너R Corner R	날 장 Length of Cut	유효장 Length of Cut Valid	전 장 Overall length	샙크경 Shank Dia
D	R	L1	-	L	d	D	R	L1	-	L	d
3.0	R0.3	4	10	60	6	6.0	R1.0	7	20	60	6
3.0	R0.3	4	16	60	6	6.0	R2.0	7	20	60	6
3.0	R0.5	4	10	60	6	8.0	R0.5	10	25	60	8
3.0	R0.5	4	16	60	6	8.0	R1.0	10	25	60	8
3.0	R0.5	4	20	60	6	8.0	R1.5	10	25	60	8
4.0	R0.3	5	12	60	6	10.0	R0.5	12	30	70	10
4.0	R0.3	5	16	60	6	10.0	R1.0	12	30	70	10
4.0	R0.5	5	12	60	6	10.0	R1.5	12	30	70	10
4.0	R0.5	5	16	60	6	12.0	R0.5	12	35	80	12
4.0	R0.5	5	20	60	6	12.0	R1.0	12	35	80	12
6.0	R0.3	7	20	60	6	12.0	R1.5	12	35	80	12
6.0	R0.5	7	20	60	6						

A'some BALL ENDMILL

-2F CARBIDE BALL ENDMILL

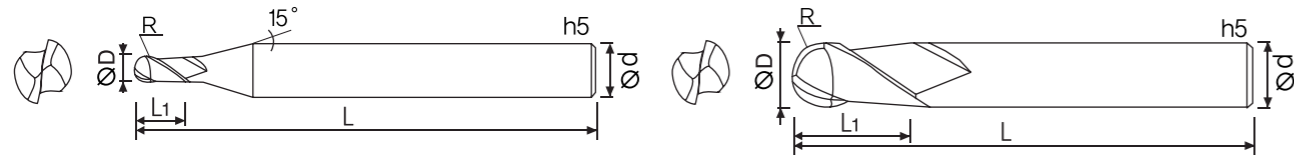
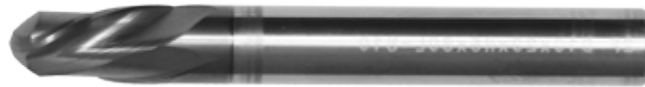

외경 Diameter	코너R Corner R	날장 Length of Cut	전장 Overall length	상크경 Shank Dia
D	R	L1	L	d
1.0	R0.5	1.2	50	6
2.0	R1.0	2.2	50	6
2.5	R1.25	3.0	50	6
3.0	R1.5	3.6	60	6
4.0	R2.0	5	70	6
5.0	R2.5	6	60/80	6
6.0	R3.0	7	60/80	6
7.0	R3.5	8	90	8
8.0	R4.0	12	100	8
9.0	R4.5	12	100	10
10	R5.0	12	70/100	10
11	R5.5	14	105	12
12	R6.0	14	80/105	12

A'some AL ENDMILL-3F

CARBIDE ALU ENDMILL



외경 Diameter	날장 Length of Cut	전장 Overall length	상크경 Shank Dia
D	L1	L	d
3.0	12 ℓ	50L	6
4.0	14 ℓ	50L	6
5.0	16 ℓ	55L	6
6.0	18 ℓ	55L	6
7.0	21 ℓ	60L	6
8.0	21 ℓ	60L	8
10.0	26 ℓ	65L	10
12.0	36 ℓ	80L	12
14.0	41 ℓ	83L	16
16.0	45 ℓ	83L	16
20.0	46 ℓ	110L	20

A'some CORNER INNER RADIUS ENDMILL

SOLID CARBIDE CORNER INNER RADIUS ENDMILL

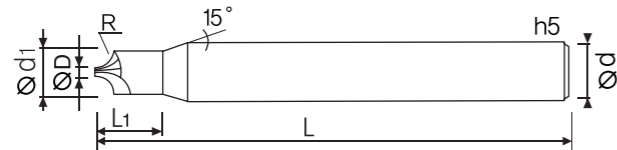

반경 Radius	직경 Dia	외경 Outer diamete	온길이 Overall Length	상크경 Shank Dia	날수 F-Type
R	D	d1	L	d	F
R0.5	1.0	2	45	6	3F
R1.0	1.9	3	45	6	3F
R1.5	1.9	5	45	6	3F
R2.0	1.9	6	45	6	3F
R2.5	1.9	7	60	8	3F
R3.0	1.9	8	60	8	3F
R4.0	1.9	10	60	10	3F
R5.0	1.9	12	60	12	3F

A'some CENTER DRILL

-CARBIDE CENTER DRILL

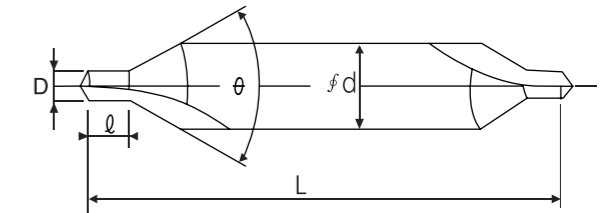

직경 Dia	날길이 Length of Cut	온길이 Overall length	상크직경 Shank Dia	각도 Angle	직경 Dia	날길이 Length of Cut	온길이 Overall length	상크직경 Shank Dia	각도 Angle
D1	ℓ	L	d	∅	D1	ℓ	L	d	∅
2	2.5	50	6	60°	4	4.8	60	8	60°
2.5	3	50	6	60°	5	6	60	10	60°
3	3.6	55	6	60°					

A'some NC DRILL

-SOLID CARBIDE NC DRILL

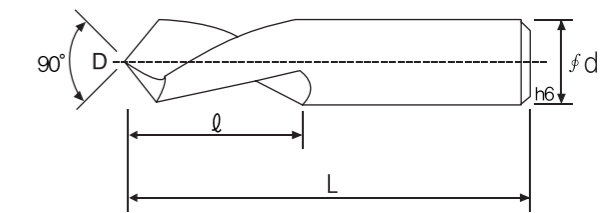

직경 Dia	온길이 Overall length	상크직경 Shank Dia	각도 Angle	직경 Dia	온길이 Overall length	상크직경 Shank Dia	각도 Angle
D	L	d	∅	D	L	d	∅
3.0	53	3	90°	8.0	64	8	90°
4.0	53	4	90°	10.0	80	10	90°
6.0	53	6	90°	12.0	80	12	90°

A'some ROUGH ENDMILL

4F CARBIDE ROUGHING ENDMILL

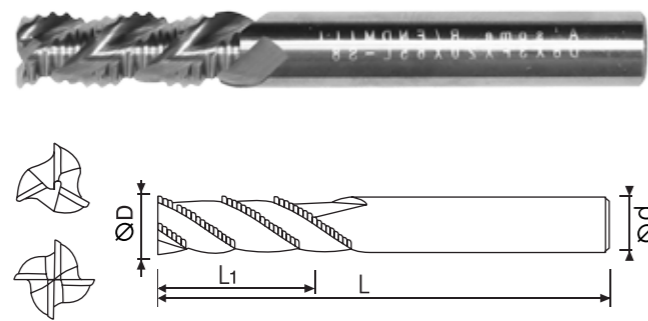

날경 Diameter	날장 Length of Cut	전장 Overall length	샤크 Shank Dia	날경 Diameter	날장 Length of Cut	전장 Overall length	샤크 Shank Dia
D	L1	L	d	D	L1	L	d
4	10	50	6	10	22	70	10
5	13	50	6	10	30	80	10
6	10	50	6	11	27	80	12
6	16	55	6	12	20	75	12
6	20	60	6	12	25	80	12
7	18	65	6	12	35	90	12
8	12	60	8	16	32	90	16
8	19	65	8	16	40	110	16
8	25	70	8	20	38	110	20
9	22	70	8	20	50	120	20
10	15	70	10				

A'some CHAMFER ENDMILL

4F CARBIDE CHAMFER ENDMILL



날경 Diameter	날장 Length of Cut	전장 Overall length	샤크직경 Shank Dia
3.0	12 ℓ	50L	6
4.0	14 ℓ	50L	6
5.0	16 ℓ	55L	6
6.0	18 ℓ	55L	6
7.0	21 ℓ	60L	6
8.0	21 ℓ	60L	8
10.0	26 ℓ	65L	10
12.0	36 ℓ	80L	12
14.0	41 ℓ	83L	16
16.0	45 ℓ	83L	16
20.0	46 ℓ	110L	20

A'some Special product ••

4F Reamer



R Cutter



Drill & Reamer

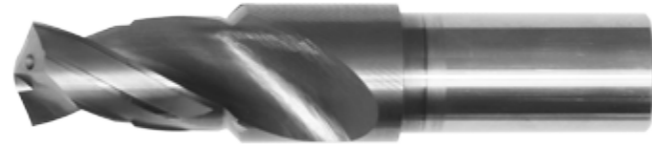

6F Chamfer Tool



Square Tube Drill



A'some Special product ••

Uneven Flute Spacing EndMill



Subland Step Drill



Triple margin drill



Chamfer



Burnishing step drill



A'some DRILL ORDER SHEET

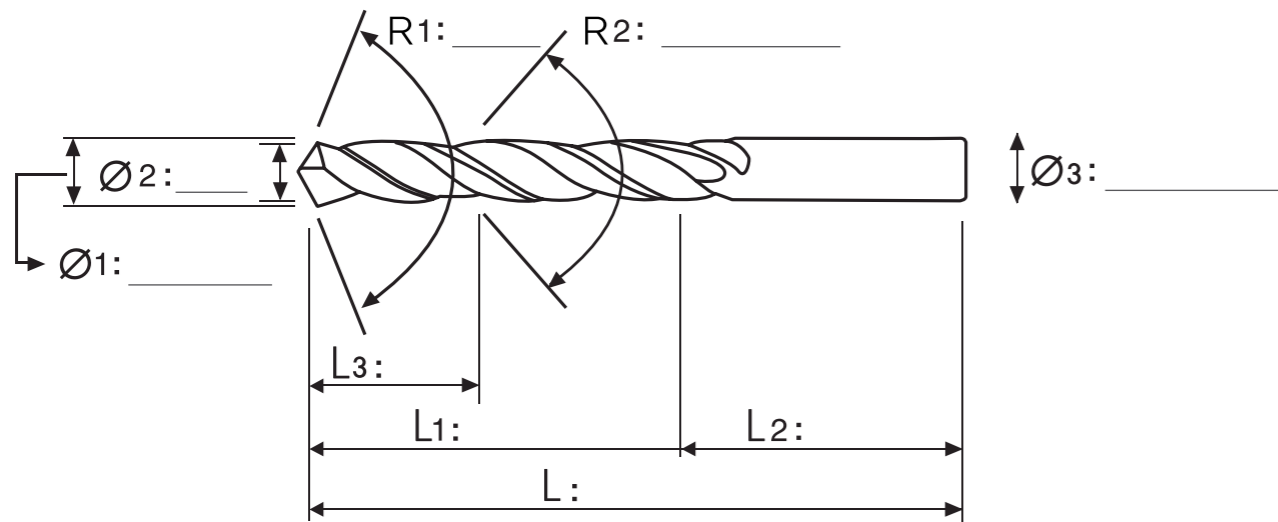
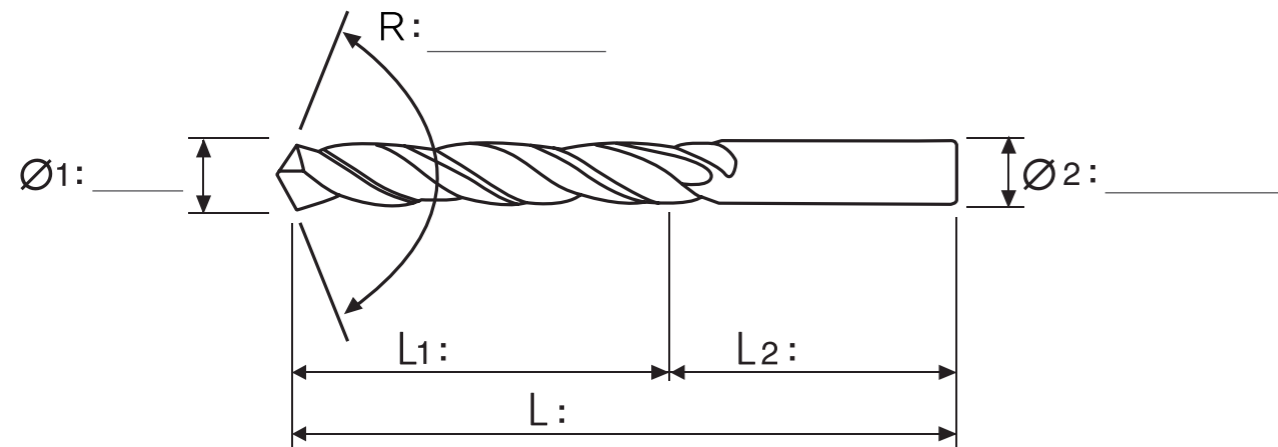

MEMO

Shank Type

- Cylindrical(원통형 샹크) -----
- Cylindrical with flat(원통형 플랫샹크) -----

Coolant Supply System

- Interner Coolant -----
- External Lubrication -----

Coating

- TiN -----
- TiALN -----
- Helica -----

Quantity

----- EA

Workpiece

Part Name : _____
 Material : _____
 Hardness : _____

Customer Name _____

Manager _____

Address _____

Phone _____

Fax _____

E-mail _____